

TR 35/25 Foot Runway Length

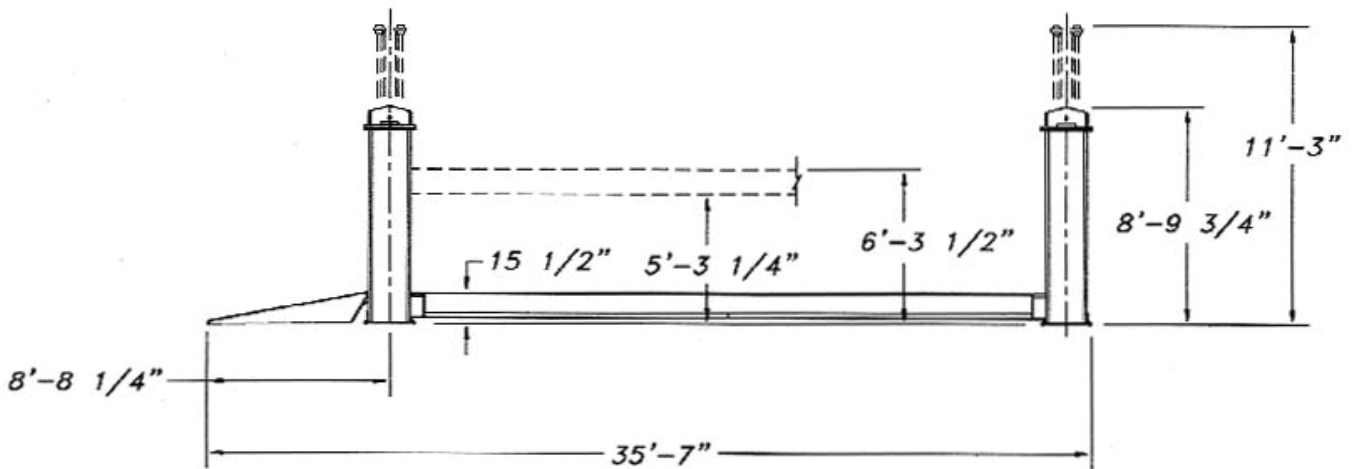

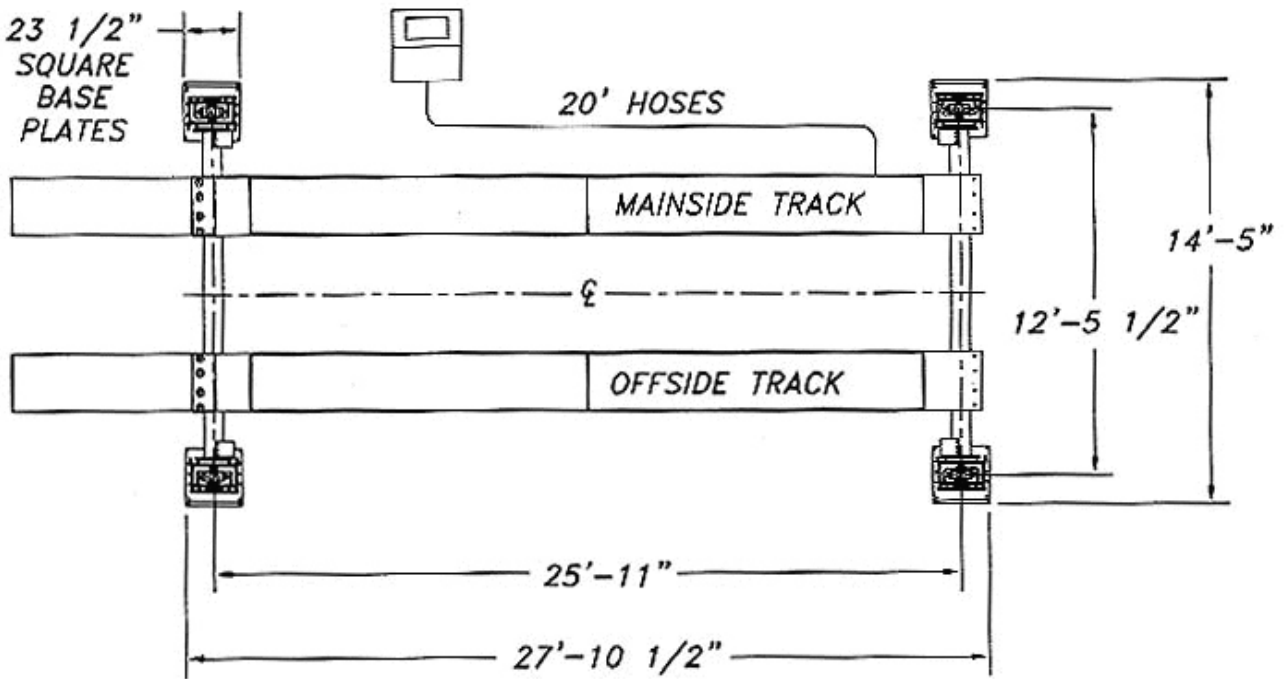
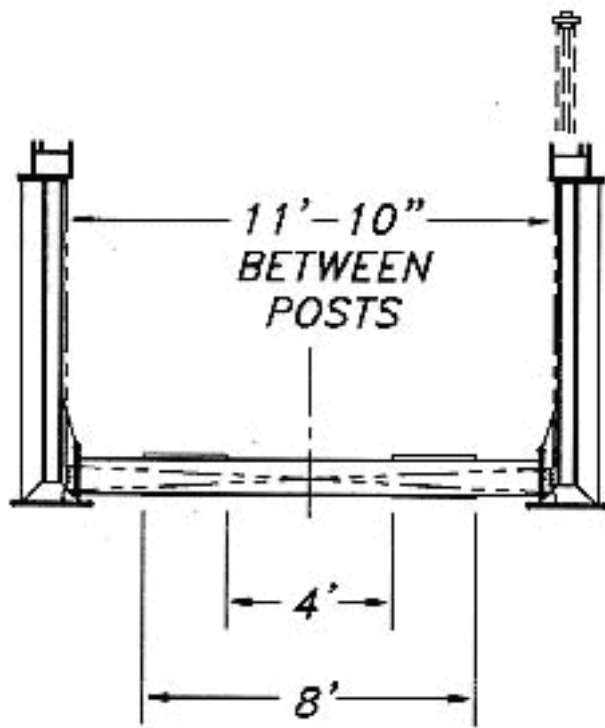

SHOWN WITH 25' RUNWAYS

MODEL:**TR-35**

Capacity:	35,000 lbs.
Lifting Speed:	120 seconds
Motor Rating:	5 HP/220 VAC, 3-phase
Lifting Height (Stroke):	5'
Runway Height at Full Stroke:	6' 3-1/2"
Weight:	14,000 lbs.
Overall Length:	35' 7"
Overall Width:	14' 5"
Width Between Posts:	12'
Track Width:	24"
Lifting Mechanism:	(4) Direct drive cylinders using no cables, chains or mechanical lifting screws.
Synchronization (Side to Side):	Hydraulic fluid displacement backed by twin opposing leaf chains.
Synchronization (fore and Aft):	Manual or automatic controls gear-type flow dividers, integral differential relief valving, and a fluid track leveling system.
Mechanical Safety Systems:	Infinite position mechanical locking wedge in each post.
Hydraulic Safety Systems:	Integral hydrostatic line blow off flow control devices and velocity fuses.
Electrical Safety Systems:	Cross-Wired Electronics Systems
Push Button Electronics:	NEMA Type 4 Waterproof
Controls:	Solenoid Operated
Wheel Chocks:	Standard Equipment
Concrete Requirements:	4000 PSI concrete 8" thick or (4) 6' x 6' footings 12" deep.
Work Area Around/Under Lift:	Clear and unobstructed when lift is raised.
Warranty:	5 years; limited lifetime on cylinders.

Available Options:

- Single Phase Power @ 208-230 VAC
- Drive Through Ramps
- Rolling Hydraulic Jacking Beams
- Air Lines Plumbed Into Tracks
- Obstacle Sensor Package
- Longer and Shorter Tracks
- Three Phase Power @ 440-480 VAC
- Runway Lighting
- Rolling Jack Platform
- Oil Drain Pan
- 4' x 4' Base Plates
-

Mohawk builds the best products with the finest materials, to the highest standards. Just compare our lifts. Our staff will assist you with a fleet evaluation, design assistance and answer any technical questions you have. We invite your calls.

Mohawk Lifts are manufactured in compliance the following standards: ANSI, ASME, AISI, ASTM, OSHA, ASA, NEC, AWS and NEMA.

Certified by Automotive Lift Institute to conform with ANSI/ALI ALCTV-1998 Standard. Meets ANSI, NEC, and NEMA safety codes.