

A 7 Rough Specifications

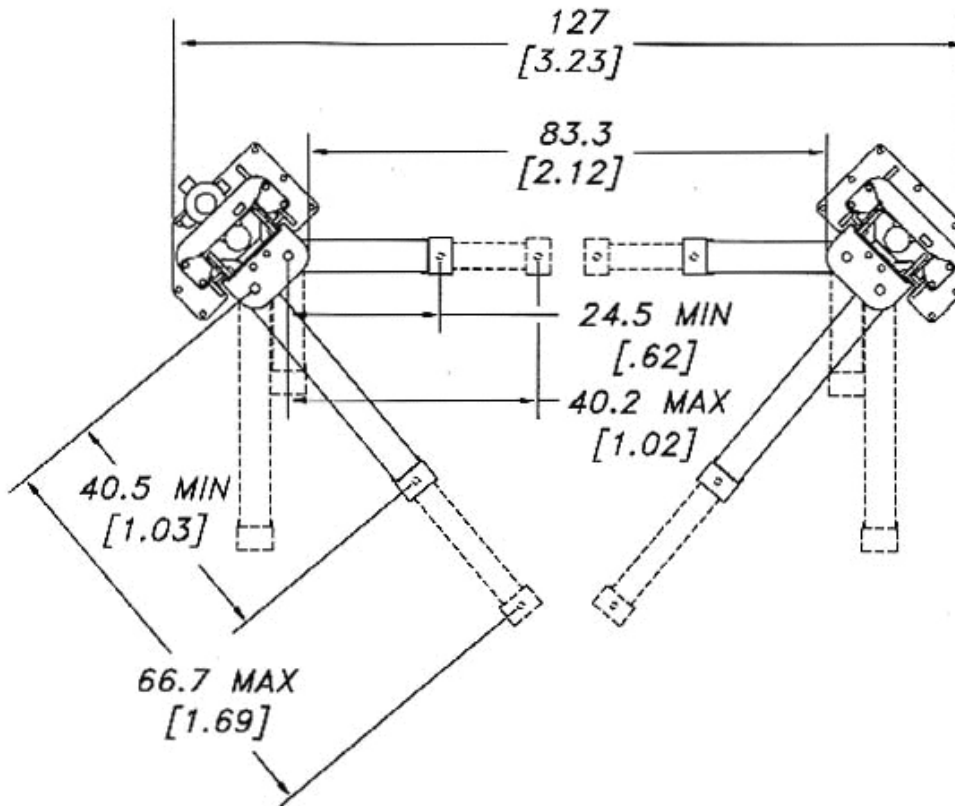
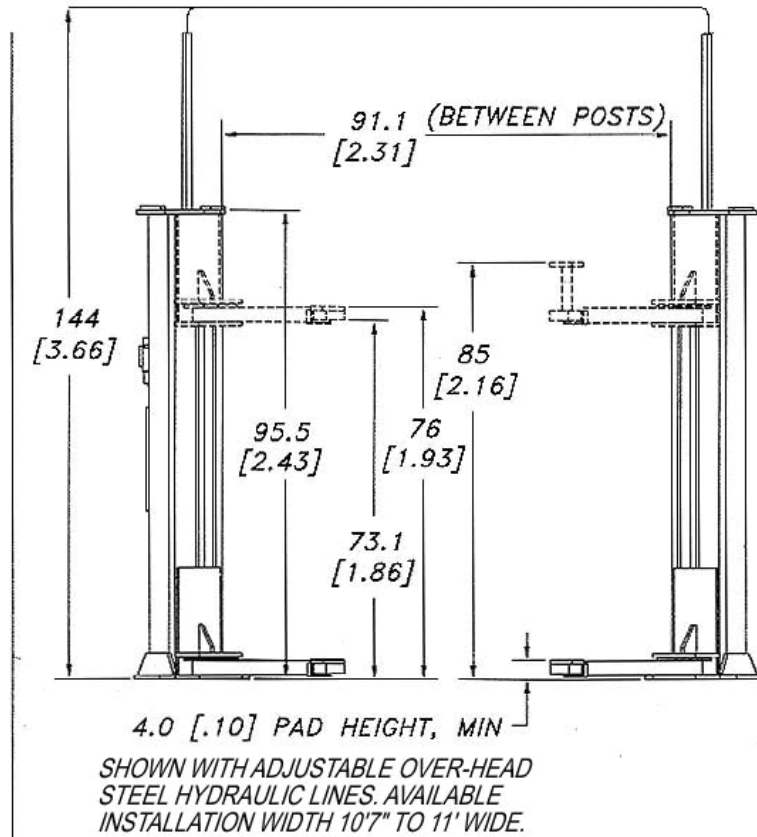

MODEL:**A-7**

Capacity:	7000 lbs. (3175.2Kg)
Lifting Speed:	45 seconds
Motor Rating:	2 HP/208-230 VAC, single-phase (3 phase optional)
Synchronization:	Hydraulic fluid displacement using no chains, cables, or overhead obstructions
Arm Pad Height:	4" (10.2 cm) minimum
Lifting Height (Stroke):	6' (1.83 m)
Arm Height @ Full Rise:	6'4" (1.93m)
Max. Pad Height with Adaptors:	7'1" (2.16m)
Overall Width:	10'7" (3.23m)(or 11'**)
Width Between Posts:	7'7-1/8" (2.31m) (or 8'1/8"***)
Width Between Carriages:	6'11-3/8" (2.12m) (or 7'4-3/8"***)
Column Height:	7'11-1/2" (2.43m)
Overall Hydraulic Line Height:	12' (3.66m) Standard (adjustable to accommodate any height ceiling or routed in-floor)
Weight:	2000 lbs. (907.2Kg)
Concrete Floor Requirements:	4000 PSI (27586.2 kPa) mix 4-1/2" (11.43 cm) depth
Anchoring System:	(14) 3/4" x 5" (1.90 x 12.7 cm) Wej-it bolts
Mechanical Safety Locks:	Automatic; all position; starting @ 3" (7.62 cm) off the floor
Hydraulic Safety Systems:	Automatic; all position
Swing Arm Restraints:	Automatic upon ascent
Cylinders:	2 (1 per column)
Drive System:	#646 leaf chain routed over cylinders
3" Frame Adaptors (stackable):	4 included as standard equipment
6" Frame Adaptors (stackable):	4 included as standard equipment
Steel Carriage Bearings:	8 per carriage, double-sealed, self lubricating
Floor Access Between Posts:	Clear and unobstructed
Warranty:	5 years; Lifetime on cylinders*

Mohawk builds the best products with the finest materials, to the highest standards. Just compare our lifts. Our staff will assist you with a fleet evaluation, design assistance and answer any technical questions you have. We invite your calls.

Mohawk Lifts are manufactured in compliance the following standards: ANSI, ASME, AISI, ASTM, OSHA, ASA, NEC, AWS and NEMA.

Certified by Automotive Lift Institute to conform with ANSI/ALI ALCTV-1998 Standard. Meets ANSI, NEC, and NEMA safety codes.

** Wider specs have not been certified by ALI/ETL