



M O D E L

TD-1000

HIGH RISE TIRE DOLLY

FOR USE WITH ALL SINGLE & DUAL TRUCK TIRES

- HEAVY DUTY
- HIGH RISE
- SIDE SHIFTING
- TIRE DOLLY

*FOR FASTER,
SAFER & EASIER
HANDLING
OF ALL
HEAVY DUTY
TIRES*

- 1000 lb. capacity
- Use with any above-ground lift or any time heavy-duty truck tires must be removed
- High 46" lifting height
- 6" side shifting ability makes alignment of lug holes simple
- Heavy-duty conveyor type rollers on lifting arms aid in realignment of bolt pattern
- When fully loaded, heavy-duty 4" steel ball bearing casters allow easy movement
- Two rear 360 degree swivel casters are equipped with caster locks
- Tilting lift arms aid axle realignment and provide additional stability to the fully loaded dolly
- Safety chain provided to secure loads
- High gear ratio brake-winch allows for easy one handed operation making tire removal and replacement a one man job
- Fully assembled & ready to

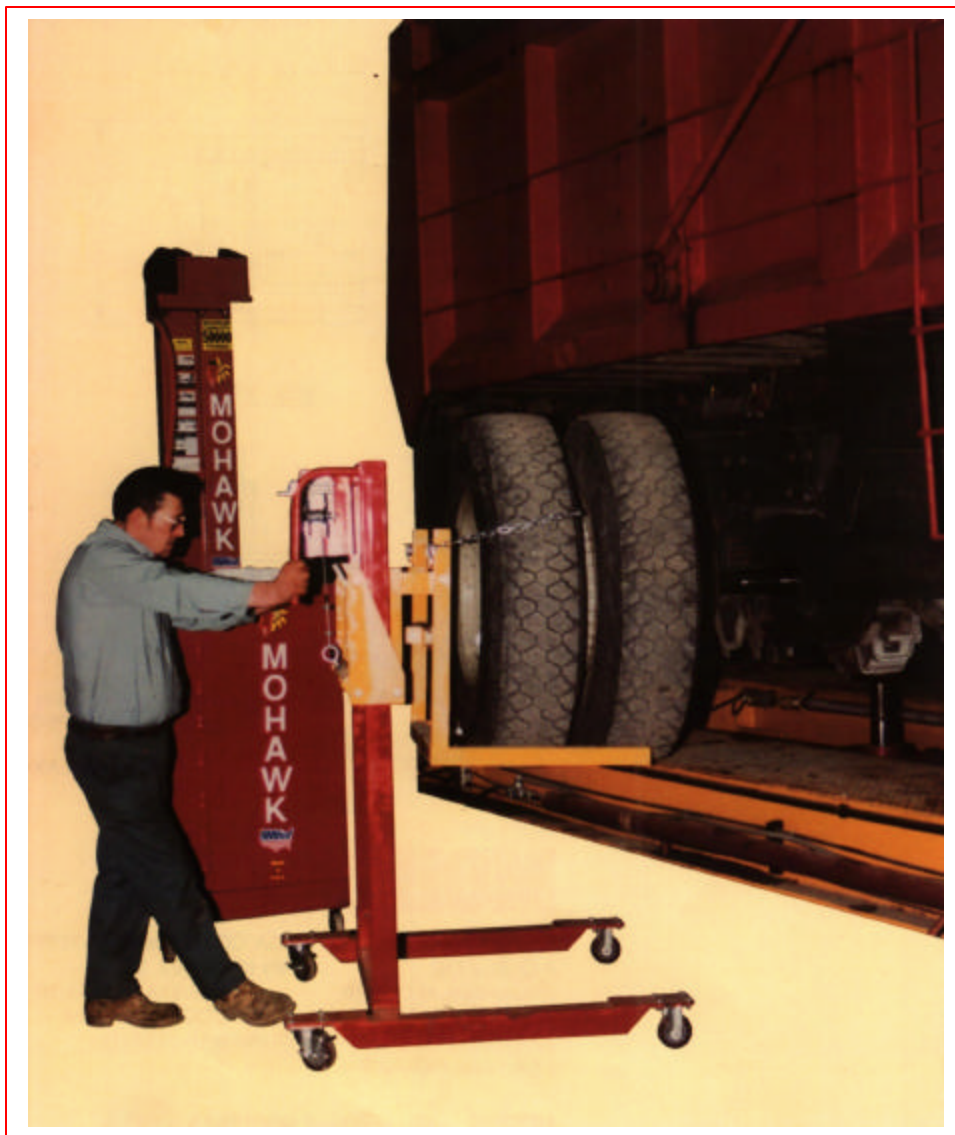

MADE IN THE U.S.A. 

MODEL TD - 1000



Capacity: 1000 lbs.
 Lifting Height: 46 1/4"
 Overall Width: 44"
 Overall Length: 44 3/4"
 Overall Unit Height: 66 1/2"
 Width of Lifting Arms: 24"
 Arm Conveyor Length: 21"
 Side Shifting Adjustment: 3" Left or Right
 Max. Arm Tilt Angle: 13°
 Min. Support Leg Clearance: 6"
 Min. Arm Elevation: 3"
 Winch Operation: Hand Crank Up & Down
 Casters: Ball Bearing Type with Locking Rear 360° Rotation
 Shipping Weight: 300 lbs.

TOP VIEW:

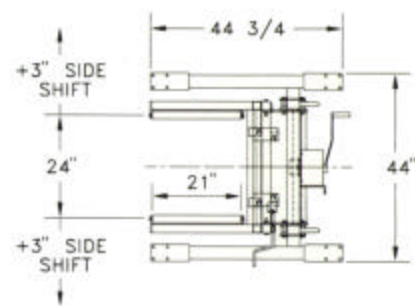

FRONT VIEW:

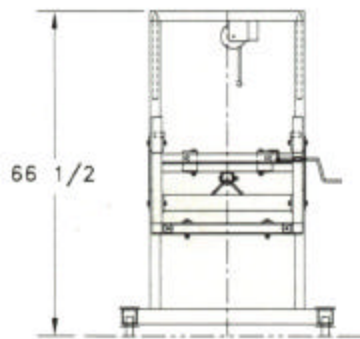

SIDE VIEW:

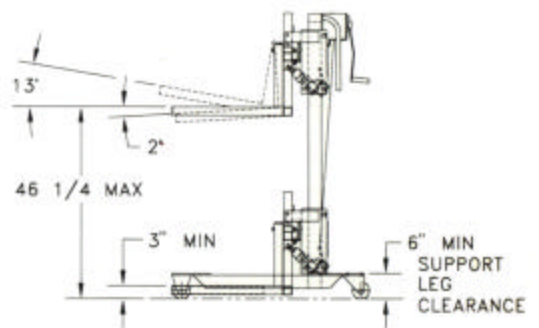

For more information on this or any other Mohawk product, E-mail Atlantic Auto Suppliers, Inc.



Mohawk Resources, Ltd.
 P.O. Box 110
 65 Vrooman Ave
 Amsterdam, NY 12010
 1-800-833-2006
 (518) 842-1431
 FAX: (518) 842-1289

GSA Contract # GSO7F-7099B
 SIN#s 253-22, 253-23, 253-23A,
 & 253-38
 CAGE CODE - OC714
 DUNS # 10-1289916

www.atlanticautosuppliers.com

Please note: Links in BLUE will only work while connected to the Internet.